

Our associates will ensure the tool works properly before you leave the store. If you experience issues with the tool while completing your project, simply bring it back to the Tool Rental Center to get a replacement. If you purchase Damage Protection at the time of your rental, you are not responsible for repair costs for tools that break due to normal use.

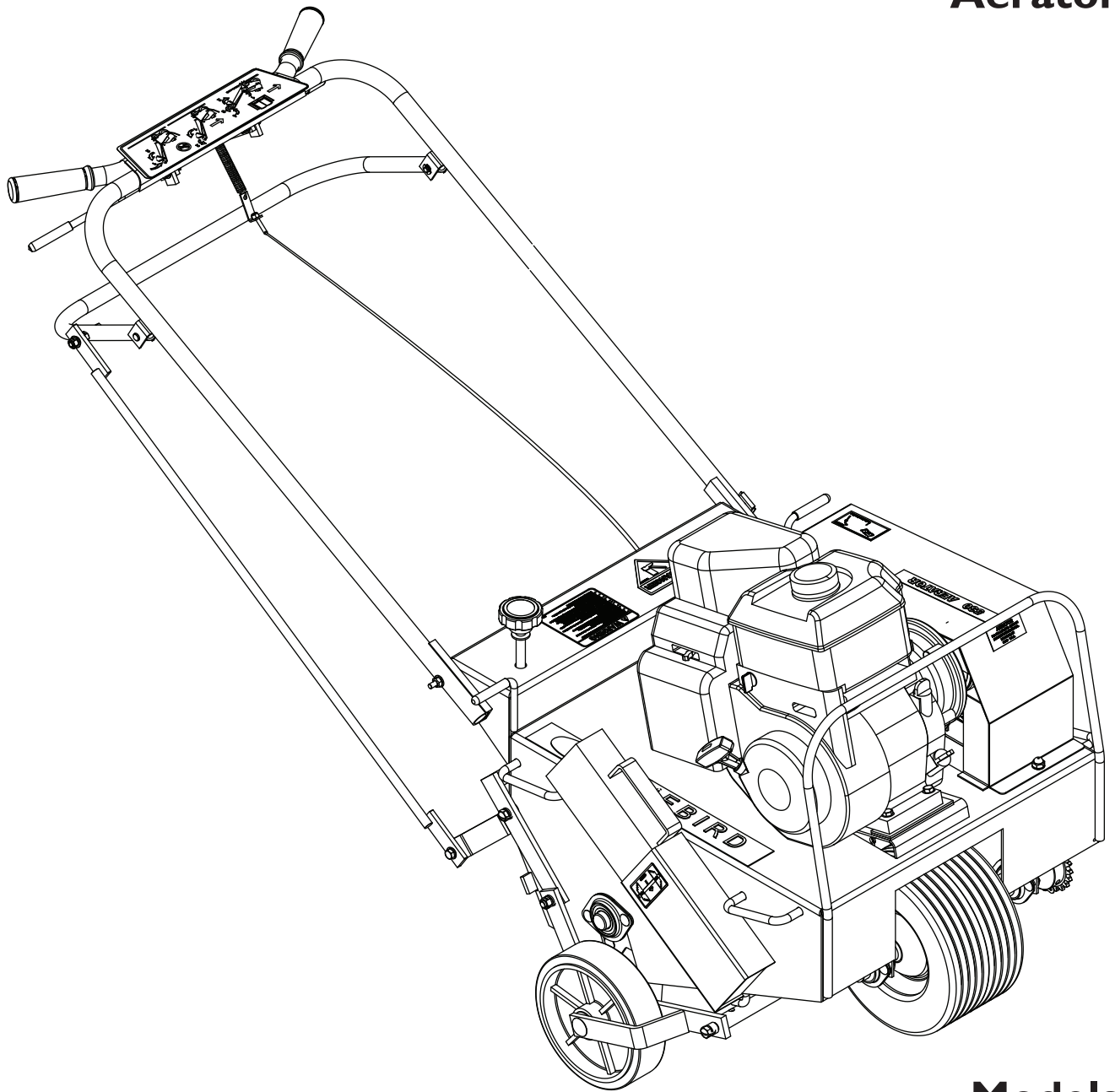



Operator Manual Aerator



Models

H424 / 968999392

H530A / 968999393

H742 / 968999394

S530B / 968999683

Please read the operator's manual carefully and make sure you understand the instructions before using the machine.



WARNING

**Engine exhaust, some of its constituents,
and certain vehicle components contain
or emit chemicals known to the State of
California to cause cancer and birth defects
or other reproductive harm.**

CONTENTS

INTRODUCTION	4	MAINTENANCE AND SERVICE	22
Use.....	4	Cleaning.....	22
Good Service	4	Two Minute Rule.....	22
Serial Number	4	Drive Train	23
SYMBOLS AND DECALS.....	5	Engine	23
SAFETY	7	Clutch Cable	24
General Information	7	Throttle Cable	24
Safety Procedures.....	7	Chain	26
General Use.....	8	Removal and Replacement	26
Preparations.....	9	Adjusting Tension.....	26
Operating.....	10	Tines	27
Movement/Transport	11	Tine Wear.....	27
Storage	11	Tine Replacement.....	27
Children.....	11	Handle	28
Fuel System	12	Wheels	29
Maintenance	13	Drive Wheel Shaft	29
ASSEMBLY	14	Rear Wheels.....	30
Models 424 and 530 Handles.....	14	TECHNICAL DATA	31
Model 742 Handle	15	Torque Specifications.....	35
Clutch and Throttle Cables	16	WARRANTY.....	36
OPERATION	17		
Aeration Tips.....	17		
Before You Start	17		
Rear Wheel Adjustment	18		
Turning And Maneuvering.....	18		
Operating On Slopes	19		
Aerating	20		
Transporting.....	21		

INTRODUCTION

Congratulations

Thank you for purchasing a BlueBird lawn care product. Through your confidence in us, you have chosen an exceptionally high quality product.

This manual is a valuable document. It describes your new BlueBird machine. Read the manual carefully before attempting to use the machine. Following the instructions (use, service, maintenance, etc.) can considerably increase the lifespan of your machine and even increase its resale value. Please contact your dealer for more information.

If you sell your BlueBird machine, make sure to give the operator's manual to the new owner.

Use

The dethatcher is used to remove the layer of thatch and surface-treat lawns, for example, power-raking, de-mossing and collecting thatch in the form of old grass or moss. With an attachment, it can also be used for seeding, both in initial sowing or overseeding.

Insure Your Machine

Contact your insurance company to check on insurance coverage for your new machine. You should have all-inclusive insurance for liability, fire, damage and theft.

Good Service

BlueBird's products are available only in specialized retail trades with complete service. This ensures that you as a customer get only the best support and service. Before the machine was delivered it underwent inspection and was adjusted by your dealer. When you need spare parts or support in service questions, guarantee issues, etc., please consult the following professional:

This Operator's Manual belongs to machine with serial number:	Engine number:

Serial Number

The machine's serial number can be found on the printed plate attached to the rear side panel of the machine. The plate includes the following information:

- The machine's type designation (MODEL).
- The machine's serial number (S/N).

Please state the type designation and serial number when ordering spare parts.

The engine's serial number is punched into the crankcase above the oil drainage screw.

The engine type is specified on the crankcase under the air filter but also appears on the decal on the starter.

Please state engine serial number and type when ordering replacement engine parts.

SYMBOLS AND DECALS

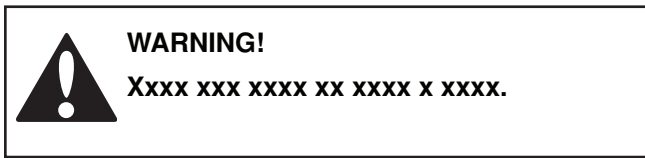

Used in this publication to notify the reader of a risk of **personal injury**, particularly if the reader should neglect to follow instructions given in the manual.

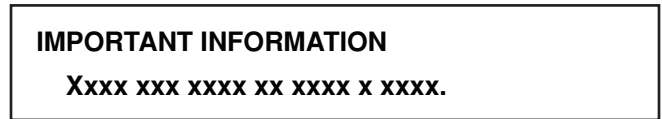

Used in this publication to notify the reader of a risk of **material damage**, particularly if the reader should neglect to follow instructions given in the manual. Used also when there is a potential for misuse or misassembly.

Decals

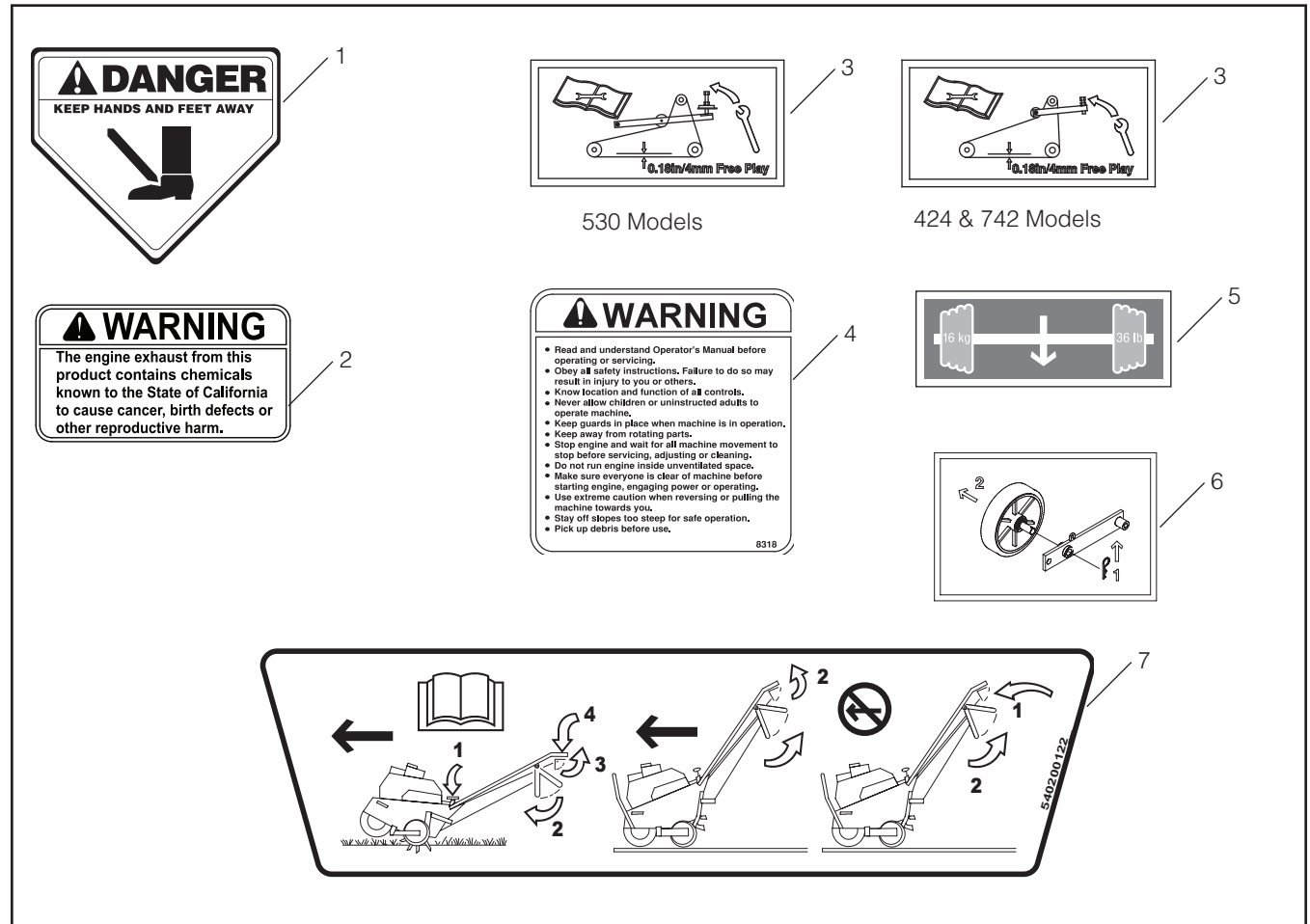

- | | |
|--------------------------------|--------------------|
| 1. DANGER watch your feet | 5. Barbells |
| 2. Warning for carbon monoxide | 6. Removable wheel |
| 3. Chain tension | 7. Controls |
| 4. Safety warnings | |

SYMBOLS AND DECALS

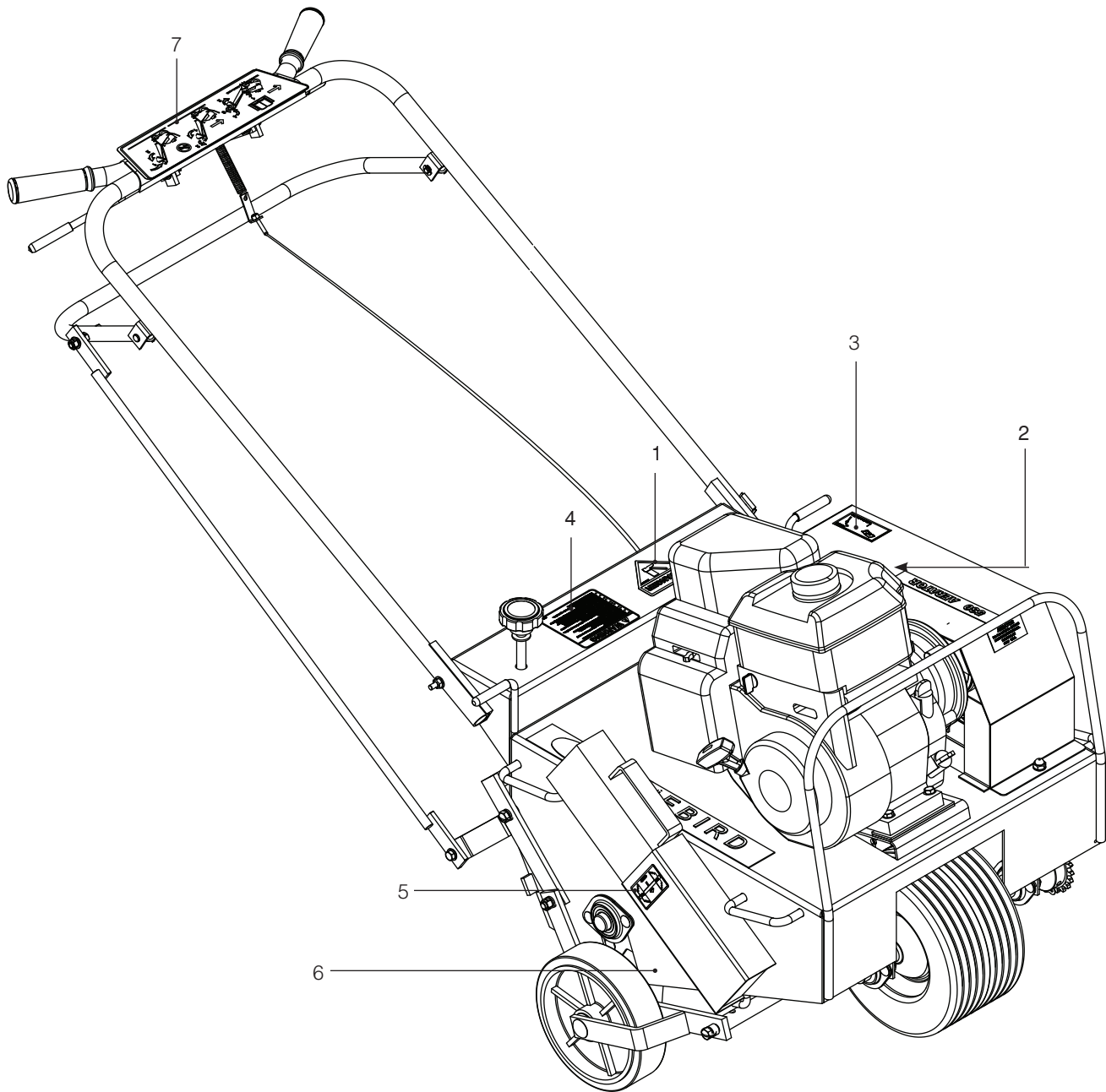

- | | |
|--------------------------------|--------------------|
| 1. DANGER watch your feet | 5. Barbells |
| 2. Warning for carbon monoxide | 6. Removable wheel |
| 3. Chain tension | 7. Controls |
| 4. Safety warnings | |

SAFETY

General Information

This manual will assist you in the safe operation and proper maintenance of your BlueBird equipment. Read it thoroughly before attempting to operate the machine. Call your dealer or BlueBird if additional information is required.

This equipment should not be modified without the manufacturer's prior written authorization. Doing so may not only affect the equipment's performance and durability, but also create safety hazards for the operator and the surroundings. Warranty will be void if changes are made to the equipment without the manufacturer's prior written authorization.

Safety Procedures

DO:

- Read all maintenance and service instructions before attempting work.
- Read engine manufacturer's operating and maintenance instructions.
- Remove spark plug wire before commencing service.
- Inspect lawn to be aerated and remove rocks, wire, string and other objects that might present a hazard before starting.
- Identify and mark all ground objects to be avoided, such as sprinkler heads, stakes, water valves, clothes line anchors, etc.
- Use machine for lawn aeration only.
- Keep unsupervised children away from the equipment.
- Adopt safe lifting and moving techniques when loading/unloading and moving the equipment.
- Make sure all decals are in place.

DO NOT:

- Do not run engine while servicing.
- Do not use on any surface other than grass.
- Do not operate on slopes exceeding 35% grade.
- Do not place hands or feet near moving or rotating parts.
- Do not lift alone.
- Do not run engine in an unventilated space.
- Do not run engine while servicing. Remove spark plug wire before commencing service.
- Do not smoke or allow open flames or sparks near unit, and always stop the engine when refueling.
- Do not remove guards when operating.
- Do not modify this equipment.
- Do not use this equipment for purposes other than lawn aeration.

SAFETY

General Use

The object of this manual is to help you use your BlueBird machine safely and to give you information about how to maintain your machine. Please read the manual carefully before attempting to use the machine.

If after reading the operator's manual you are still unsure about the safety risks associated with use of the machine, you should not use the machine. Please contact your dealer for more information.

These safety instructions only address the basics for safe use. It would be impossible in the safety instructions to describe all possible risk situations that could arise when using the machine. You can, however, prevent accidents by always using common sense.

For a replacement copy of the operator's manual, contact your dealer.

IMPORTANT INFORMATION

Do not use the machine until you have read the operator's manual carefully and understand the instructions given. All maintenance work or adjustments not described in this manual must be performed by an authorized BlueBird service workshop.

- Read this manual carefully and make sure you understand it before using the machine or performing any maintenance. If the user cannot read this manual, it is the responsibility of the machine owner to explain the contents to the user.
- Follow all safety instructions. Failure to do so may result in injury to yourself or others.
- Accident prevention regulations, other general safety regulations, occupational safety rules and traffic regulations must be followed without fail.
- All users shall be trained in use of the machine. The owner is responsible for training users.
- Engage an authorized BlueBird workshop for all service and repairs not described in this manual.
- BlueBird original spare parts are designed and specified to maintain high quality and correct fit for optimal durability and lifespan.
- Check that all safety decals are in place. See the chapter "Symbols and Decals".
- Learn how to use the machine and its controls safely and learn to recognize the safety decals.
- Only use the machine for aerating lawns. It is not intended for any other use.



WARNING!

Under no circumstances may the original design of the machine be modified without written approval from the manufacturer. Such modifications not only affect the performance and durability of the machine but may even pose a safety risk for users and those in the vicinity. Unauthorized modifications to the design of the machine may absolve the manufacturer from liability for any resulting personal injury or property damage. Modifying the machine without written approval from the manufacturer may void the guarantee.

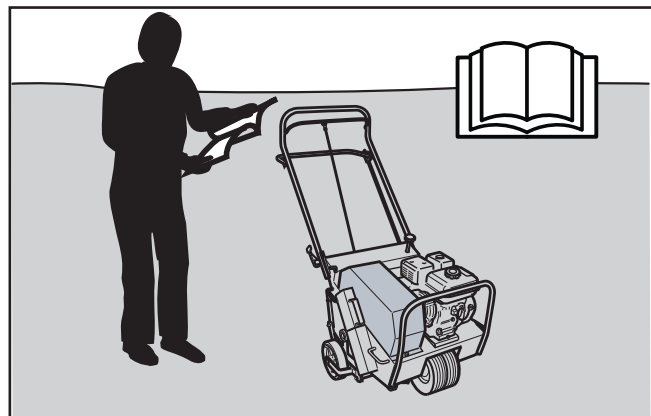

8060-055

Read this manual carefully before starting the machine.



WARNING!

Overexposure to vibration may lead to circulatory or nerve damage, particularly in people who have impaired circulation. Contact your doctor if you experience symptoms that could have been caused by overexposure to vibration. Examples of common symptoms include numbness, pain, muscle weakness, change of skin color or an uncomfortable feeling of tingling. These symptoms appear most frequently in the fingers, hands or wrists.

SAFETY

- Check that the machine is in serviceable condition prior to use; see the chapter “Maintenance/ Maintenance schedule”.
- Only use the machine in daylight or in other well-lit conditions. Keep the machine a safe distance from holes or other irregularities in the ground. Pay attention to other possible risks.
- Only allow the machine to be used by adults who are familiar with its use.
- Never allow children or persons not trained in the use of the machine to use it. Local laws may regulate the age of the user.
- People and animals can distract you causing you to lose control of the machine. For this reason, always concentrate and focus on the task at hand. Make sure animals and people maintain a safe distance from the machine.
- Never leave the machine unsupervised with the engine running.
- Make sure that other people are nearby when you are using the machine so that you can call for help should an emergency arise.
- The machine is tested and approved only with the equipment originally provided or recommended by the manufacturer.

Preparations

- Have first aid equipment at hand when using the machine.
- Make sure no one else is in the vicinity of the machine when starting the engine, engaging the drive or running the machine.
- Clear the area of objects such as rocks, toys, wire, etc., which could be picked up and thrown by the blades.
- Locate fixed objects in the ground, such as sprinkler systems, poles, water valves, bases for washing lines. Check for hidden electrical cables or similar in the surface of the lawn. Run the machine around these objects. Never intentionally run the machine over foreign objects.
- Make sure all guard plates and protective shields are in place and intact when using the machine.
- Make sure no clothing, long hair or jewelry can catch in moving machine parts.
- Never use the machine when barefoot. Always wear protective shoes or protective boots with anti-slip and preferably with steel toes.
- Wear approved ear-protection when running the machine. Ask your dealer about approved ear-protection.



WARNING!

The engine can become very hot. To avoid being burned, you must turn off the engine and wait until all parts have cooled before touching the engine.

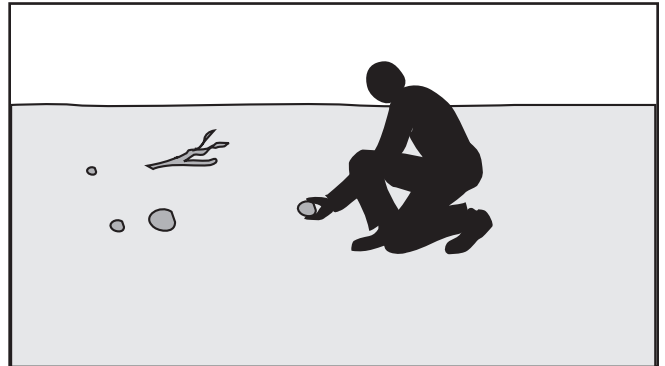

8011-198



WARNING!

Always use approved protective clothing and approved protective equipment when using the machine. Protective clothing and protective equipment cannot eliminate the risk of accidents, but wearing proper clothing and the correct equipment will reduce the degree of injury should an accident occur. Ask your dealer about approved protective clothing and approved protective equipment recommended by BlueBird.

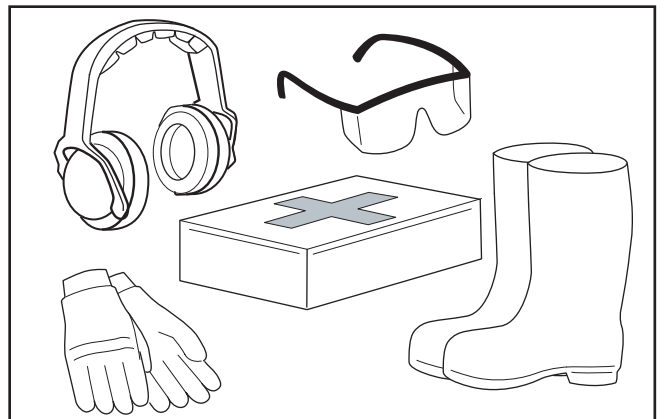

8011-670-aRunning

SAFETY

Operating

- Do not use the machine on grades of more than 20°. We recommend working across slopes rather than up and down. This will yield a more even result. Do not leave the machine standing on a slope unattended.
- Do not use the machine if you are tired, if you have consumed alcohol, or if you are taking other drugs or medication that can affect your vision, judgment or co-ordination.
- Never use the machine indoors or in spaces lacking proper ventilation.
- Do not use the machine on any surface other than grass.
- Make sure you have a proper foothold when using the machine, particularly when backing. Walk, don't run. Never work on wet grass. Poor traction may cause you to slip.
- Keep your hands and feet away from moving parts.
- Keep your hands and feet away from the work tools.
- Slow down and be especially careful on slopes. Make sure to run the machine in the recommended direction on slopes. Be careful when working close to sudden changes in level.
- Smoking, open flames or sparks in the vicinity of the machine are strictly forbidden. Gasoline is extremely flammable and carelessness in handling can result in personal injury or fire.
- Stop and inspect the equipment if you run over or into anything. If necessary, make repairs before beginning again.
- Whatever happens, you should always park the machine on even ground, disengage the drive, turn off the engine and wait until all moving parts have stopped before leaving the operating position behind the machine.

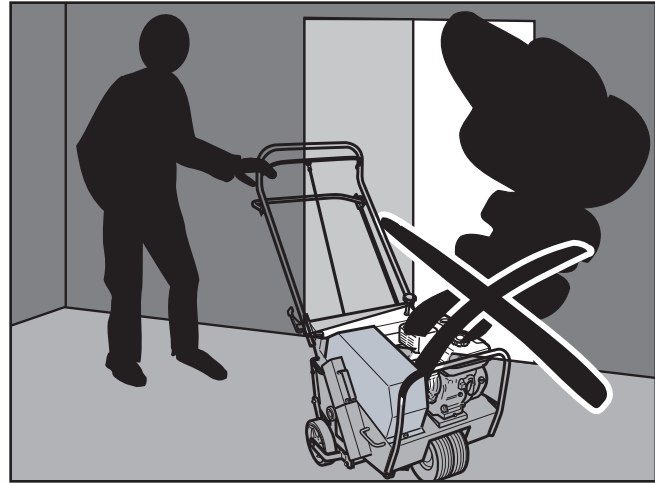

8060-054

The engine exhaust is poisonous. Never run the engine indoors.



8011-091

Keep your hands and feet away from moving parts.

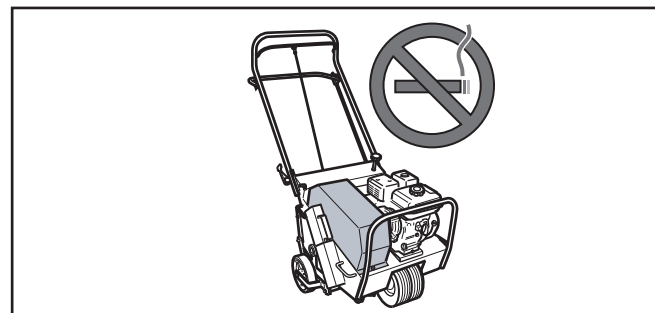

8060-056

*Smoking near the machine is **strictly** prohibited.*



WARNING!

Engine exhaust, some of its constituents and certain vehicle components contain or emit chemicals considered to cause cancer, birth defects or other reproductive harm. The engine emits carbon monoxide, which is a colorless, poisonous gas. Do not use the machine in enclosed spaces.

SAFETY

Movement/Transport

- To turn and steer the machine, press down on the handle and turn on the back wheels.
- Turn off the engine and allow it to cool at least 2 minutes before transport.
- Collapse the handle if the machine is equipped with a collapsible handle.
- Be careful and use safe lifting and moving techniques when loading/unloading the machine.
- We recommend having two people to lift the machine.
- Fasten the machine properly in place with approved fasteners, such as tension belts, chains or rope. Always check that you are in compliance with applicable traffic regulations before transporting the machine.

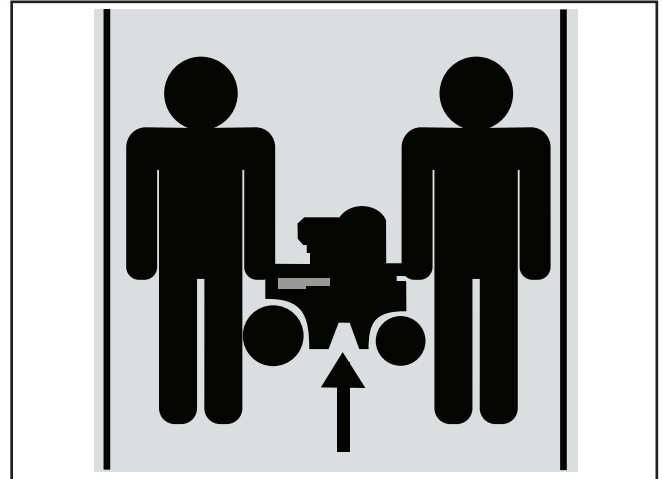

8011-090

We recommend having two people to lift the machine.

Storage

- Allow the engine to cool before storing the machine. Never store the machine near a open flame.
- Store the machine with the fuel valve closed.
- Store the machine and fuel in such a way that there is no risk that leaking fuel or fumes can come in contact with flames or sparks from electrical machines, electric engines, relays, switches, boilers or similar.
- Store the machine in a locked space away from children and adults untrained in use of the machine.

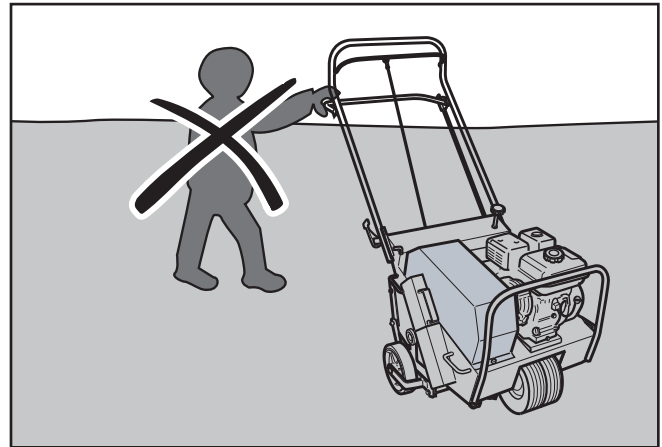

8060-057

Keep children away from the machine.

Children

Serious accidents can occur if you fail to be on guard for children in the vicinity of the machine. Never assume that children will stay put where you last saw them.

- Keep children away from the machine.
- Keep children away from the work area and under close supervision by another adult.
- Keep an eye out and shut off the machine if children enter the work area.
- Never allow children to operate the machine.
- Be particularly careful near corners, bushes, trees or other objects that block your view.

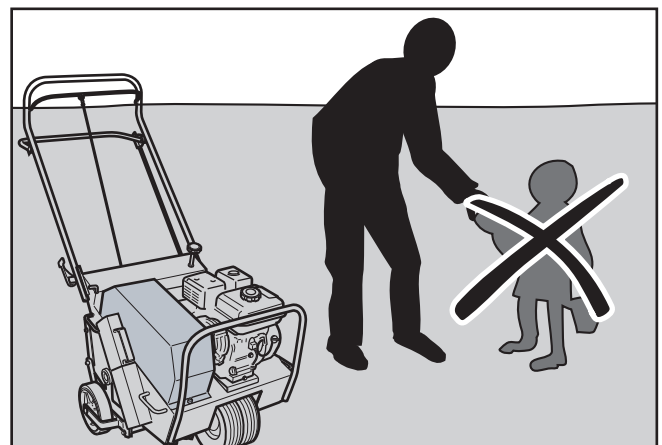

8060-058

Keep children away from the work area.

SAFETY

Fuel System



WARNING!

Gasoline and gasoline fumes are poisonous and extremely flammable. Be especially careful when handling gasoline, as carelessness can result in personal injury or fire.

- Only store fuel in containers approved for that purpose.
 - Never remove the fuel cap and fill the fuel tank when the engine is running.
 - Always stop the engine when refueling.
 - Do not smoke when filling the gasoline tank and do not pour gasoline in the vicinity of sparks or open flame.
 - Never fill the fuel tank indoors.
-
- Before starting the machine after refueling, it should be moved at least 10 feet (3 M) from the location where it was filled.
 - Turn off the fuel supply for storage or transport.
 - If leaks arise in the fuel system, the engine must not be started until the problem has been resolved.
-
- Check the fuel level before each use and leave space for the fuel to expand, because the heat from the engine and the sun can otherwise cause the fuel to expand and overflow.
 - Avoid overfilling. If you spill gasoline on the machine, wipe up the spill and wait until it has evaporated before starting the engine. If you spill gasoline on your clothing, change your clothing.



8060-059

Never fill the fuel tank indoors.

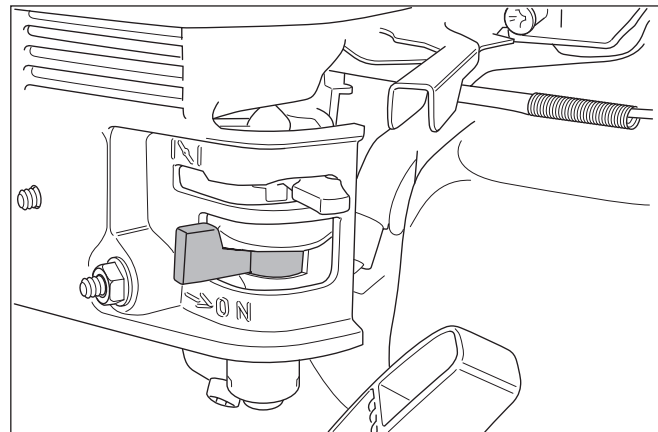

8011-036

Close the fuel valve.

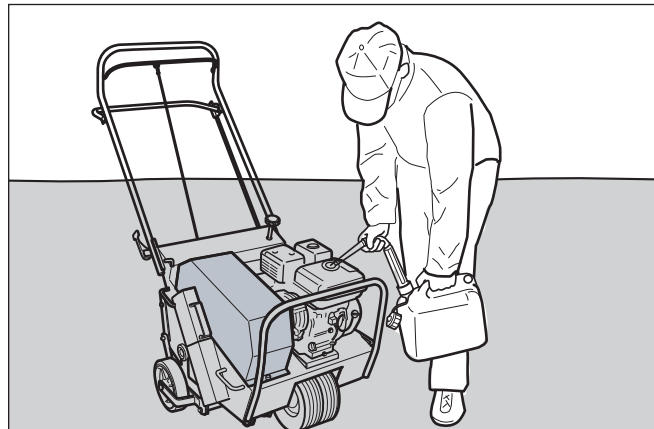

8060-060

Fueling always poses an element of risk.

SAFETY

Maintenance

- Never make adjustments with the engine running.
- Disengage the drive units, shut off the engine and wait until all moving parts come to a complete stop before making adjustments, performing maintenance or cleaning the machine.
- Disconnect the spark plug cable before beginning repair work.
- Keep all components in serviceable condition and make sure all nuts, bolts, etc. are tight. Replace worn or damaged decals.
- Be careful when checking work tools. Use gloves when performing maintenance work.
- Never allow persons not trained in the use of the machine to perform service on it.
- Always park the machine on even ground before performing maintenance or making adjustments.
- Do not disassemble the engine. This can invalidate your engine warranty. Contact your dealer if you have any questions regarding service or guarantee matters. Follow all maintenance instructions.
- Do not change the setting of governors and avoid running the engine with overly high RPM. If you run the engine too fast, you risk damaging the machine components.
- Do not modify safety equipment. Check regularly to be sure it works properly. The machine must not be run with defective or disassembled safety equipment.
- The muffler is designed to maintain sound levels at an approved level and keep direct exhaust away from the user. Exhaust gases from the engine are extremely hot and may contain sparks that can cause fires or burn the user.
- Never use a machine with a defective muffler.
- Reduce the risk of fire by removing grass, leaves and other debris that may have caught in the machine.

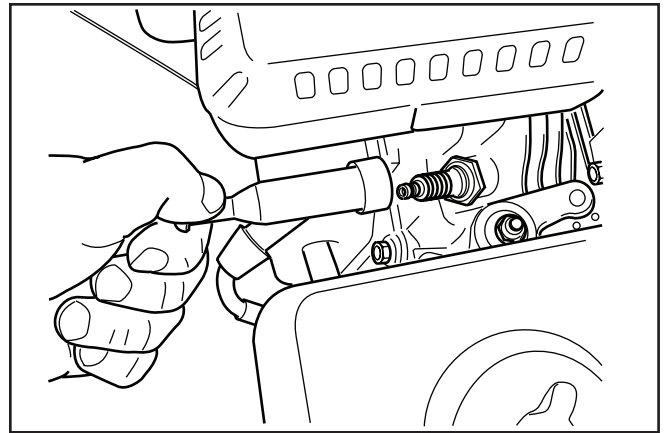

8011-027

Disconnect the spark plug cable before repair work.



WARNING!

Wait until all moving parts are completely still before performing maintenance on the machine.

Turn off the engine and remove the spark plug cable.



8060-061

Keep the machine clean.

ASSEMBLY



CAUTION!

Use protective glasses when removing unit from crate.

Models 424 and 530 Handles

1. The aerator is shipped with the handle folded. Rotate handle into upright position and lock, using the cam lock lever or link lock (dependent on model).

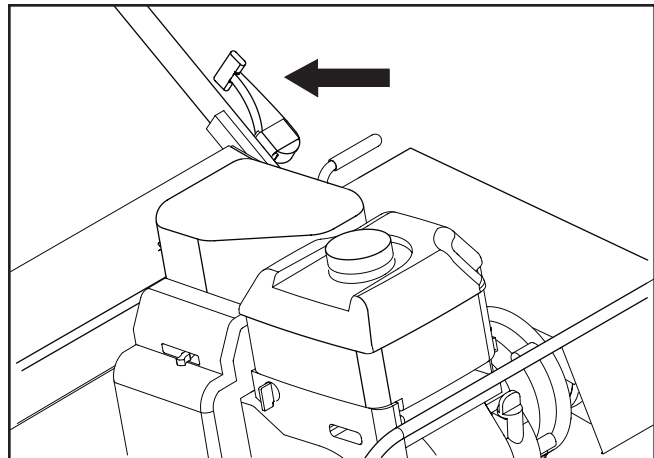

8060-001

Locking cam for handle

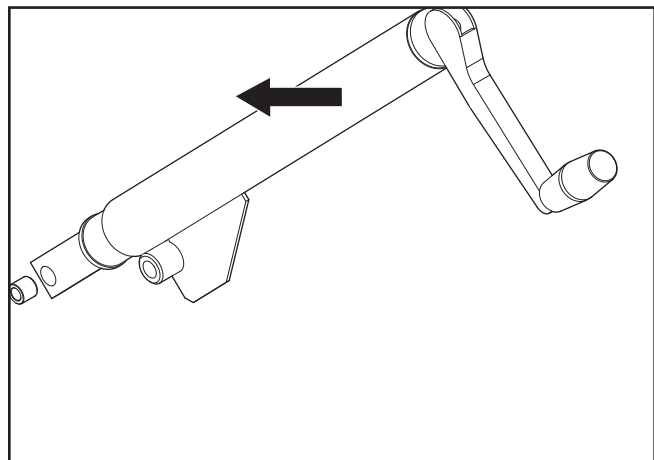

8060-001

Locking link for handle

2. **Cam Lock** - Connect the top of control rod to rear wheel control handle with the fasteners located on the rear wheel control handle, using the back holes. (See illustration)
Link Lock - Connect the top of control rod to rear wheel control handle with the fasteners located on the rear wheel control handle, using the front holes. (See illustration)

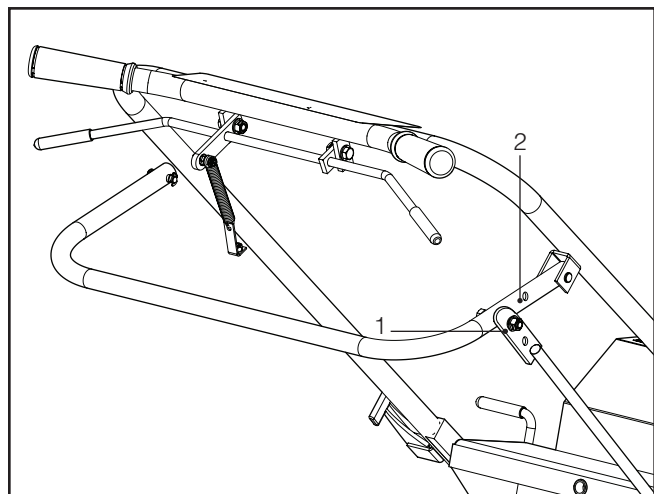

8060-003

1. Cam lock assembly location
2. Link lock assembly location
Connecting control rod

ASSEMBLY

Model 742 Handle

3. The aerator is shipped with the handle detached. Mount the handle using two ½" wrenches.
 - a. Slide handle onto handle mounting brackets.
 - b. Insert and tighten fasteners, which are located on handle mounting brackets.

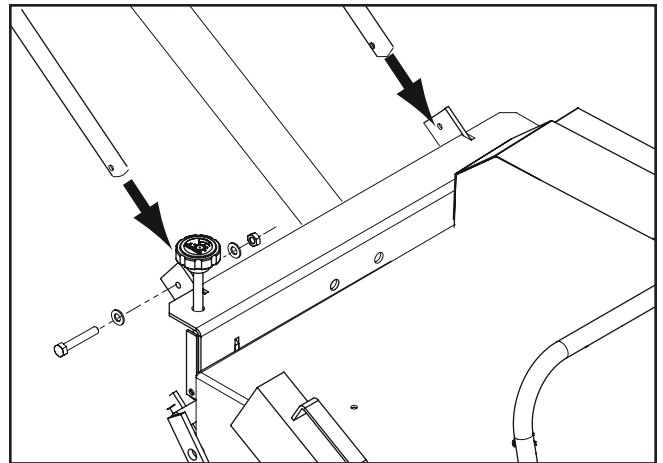

8060-033

Attaching non-folding handle

4. Connect top of control rod to rear wheel control handle with fasteners located on rear wheel control handle using the upper hole on the control rod.

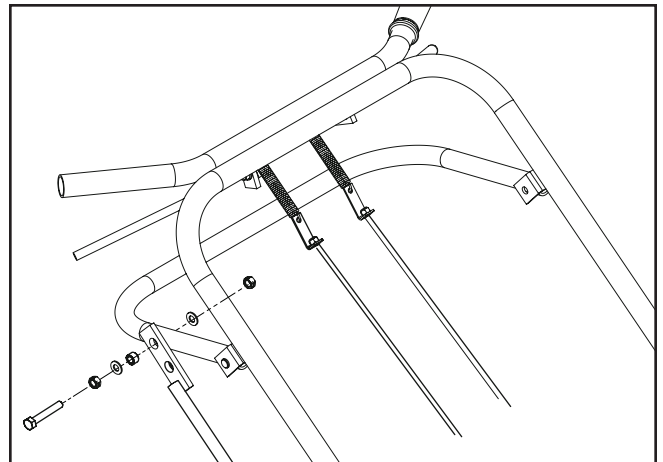

8060-033

Connect upper control rod

5. Connect bottom of control rod to OUTER side of lever on the torque arm through the lower hole, using the fastener assembly.

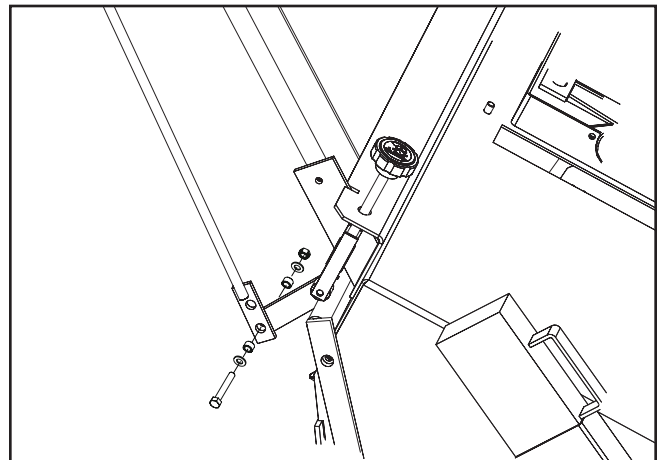

8060-035

Connect lower control rod



CAUTION!

Be certain that the clutch cable is properly routed.

ASSEMBLY

Clutch and Throttle Cables

6. Run the clutch cable through the guide hole in the handle bracket support bar located at the rear of the deck.
7. Attach the end of the cable to the S hook located on the belt idler pulley.



CAUTION!

Be certain that the clutch cable is properly routed.

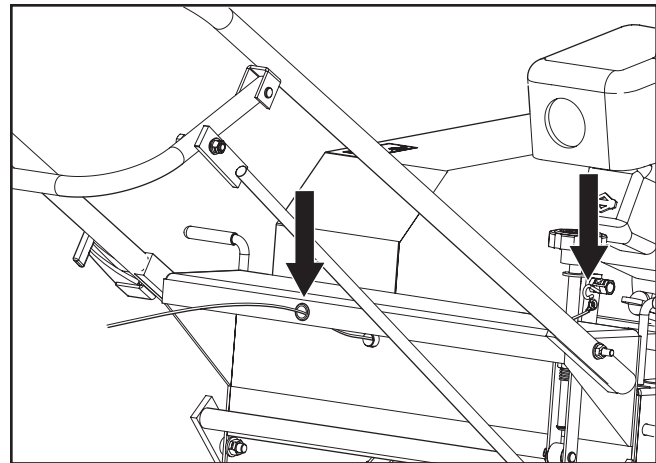

8060-002

Route clutch cable through guides

8. 742 Honda Engines Only - The throttle cable has been installed by the factory, however the throttle spring needs to be connected to throttle/clutch control lever.

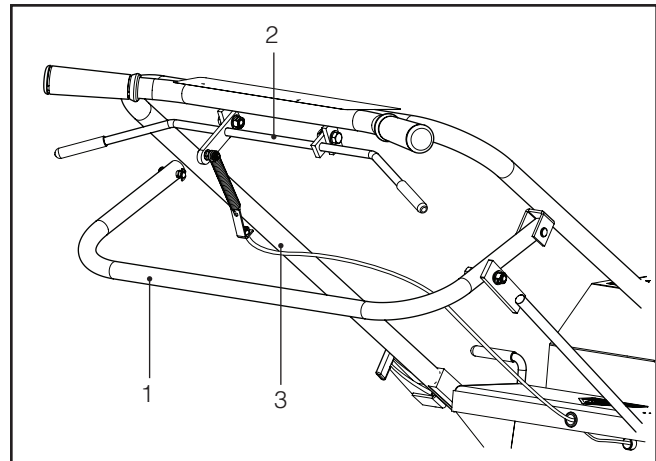

8060-006

1. Rear wheel control handle
2. Clutch handle
3. Handle

Check controls before starting

OPERATION

Aeration Tips

Watering Before Aerating

The best aerating condition is soft, moist ground. If unsure of the ground conditions, as in soil with high clay content, test to determine whether it is necessary to water before aerating.

Push a garden hand spade or large screw driver into ground. The tool should drive in 2-3 inches with little effort. If unable to do so, watering the lawn a day before aerating is necessary.

Using Removable Weights

Soil conditions dictate whether extra machine weight is needed for effective coring action. The weights are provided to give added control and greater tine penetration.

Before You Start

1. Ensure that the engine oil and gear reduction oil levels are at the engine manufacturer's recommended level (refer to engine manual). The machine must be level when filling with oil.
2. With the folding handle in its operating position, lock the handle cam lock or link lock. (Models 424 & 530).
3. The rear wheel control handle must be pulled up so rear wheels are fully down.
4. Insert weights if needed.
5. Check that the handle is properly mounted.
6. Test the clutch handle to ensure that the clutch releases freely.
7. The engine top speed is preset by the engine manufacturer. Consult the engine manufacturer's manual for instructions to adjust the governor and carburetor if the speed is not within correct range.



WARNING!

NEVER cross hard objects or surfaces (sidewalks, driveways, stepping stones) with tines down.

OPERATION

Rear Wheel Adjustment

The rear wheel depth/stability control knob allows adjustment for better stability and maneuverability when the knob is turned in a clockwise rotation

Adjustments for depth are made by turning the knob counterclockwise. This adjustment determines the length of the cores pulled by:

- Adjusting the rear wheels to a desired level to control the penetration of the tines to within a fraction of an inch.
- With the rear wheels in the “fully up” position, maximum tine penetration is gained. Pushing down on the machine’s handle bars puts most of the weight of the machine on the tines. This results in pulling the longest cores.

NOTE: Adjusting for greater stability gives greater side-to-side control and will improve maneuverability during aeration. (See “Operating on Slopes.”) Adjustments for stability will shorten the length of the cores pulled.

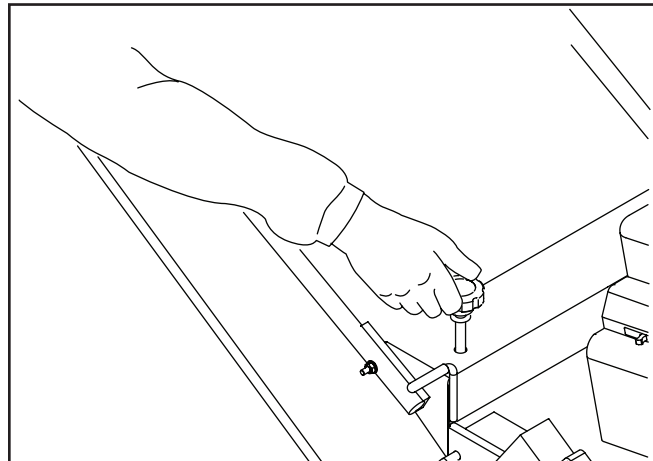

8060-008

Control depth and stability with rear adjustment knob



WARNING!

This method is NOT recommended when operating on slopes.



CAUTION!

NEVER cross hard objects or surfaces (sidewalks, driveways, stepping stones, etc.) with tines down.

Turning And Maneuvering

Gradual maneuvering while aerating can be accomplished by carefully guiding the machine. It is recommended to adjust the engine’s speed control to allow for a comfortable walking speed and maintaining complete control while working in tight spaces. Adjusting for more stability (with the rear wheels lowered, reducing tine penetration) will make turning easier.

When reversing direction or making sharp turns, select the safest and most comfortable method for the conditions you face:

- Release clutch control handle, pull up rear wheel control handle, then pivot machine on rear wheels to turn.
- Release clutch control handle, lift handle bar and pivot machine on front wheel.



WARNING!

DO NOT operate on slopes exceeding 35% grade.



WARNING!

In extreme situations (very steep slopes) the machine may be unbalanced and present the danger of rolling over.

OPERATION

Operating On Slopes

This unit is not designed to be used on steep slopes. Be aware that when operating on slopes the tilt of the aerator will cause the machine's center of gravity to shift to the downhill side of the machine. Under these circumstances you may experience:

- the need to exert a greater effort to steer and maintain the balance of the machine.
- uneven tine penetration, when operating across a slope. Due to the shifted center of gravity the downhill tines will penetrate to the maximum depth, while uphill tines may not.

When operating on slopes:

- operate the machine up and down the slopes instead of across.
- use the rear adjustment knob to set the rear wheels for extra stability. This can be a great benefit when you do need to run the aerator across a slope. Additionally, using the depth control when aerating across a slope improves the consistency of the cores pulled from the uphill tines when compared to those pulled by the downhill tines.
- remove the downhill side weight to reduce rollover risk and maintain consistent core plug length.
- move remaining weight from downhill side to uphill side after each pass when operating across slopes.

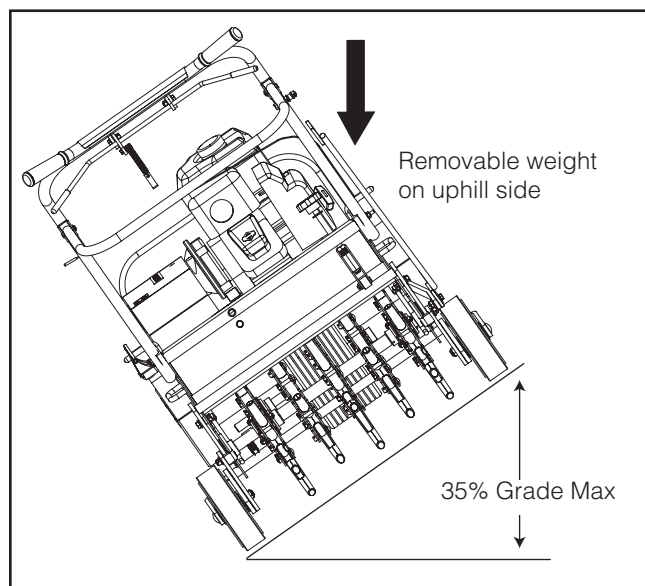

8060-007

Place weight on uphill side of slope



WARNING!

NEVER disengage tines from ground when traveling uphill or downhill. ONLY disengage on a flat surface.

OPERATION

Aerating

1. Start engine and adjust throttle setting to provide comfortable walking speed and maintain control of the equipment at all times.
2. Adjust depth control knob to desired depth. Coring depth decreases by turning the knob clockwise. NOTE: raising rear wheels all the way up to obtain maximum coring depth reduces the unit's stability but increases length of core.

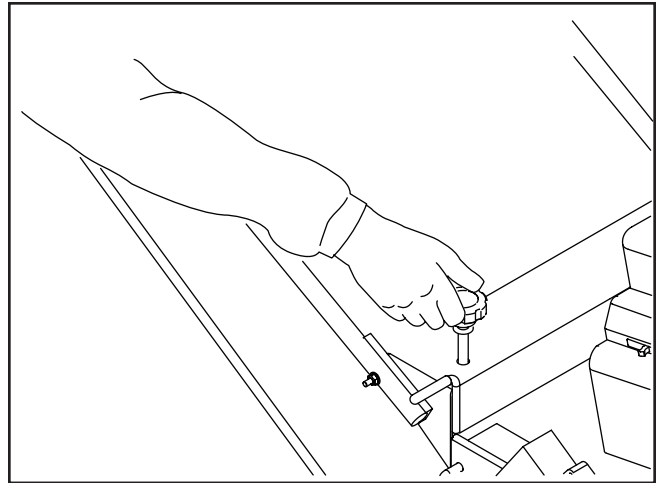

8060-008

Adjust depth control knob

3. Push down the rear wheel control handle to lower aerating tines into the ground (rear wheels will rise).
4. Push down on handle bar for better tine penetration and maneuverability (front wheel will rise).
5. Engage clutch control.
6. To stop, release clutch control.

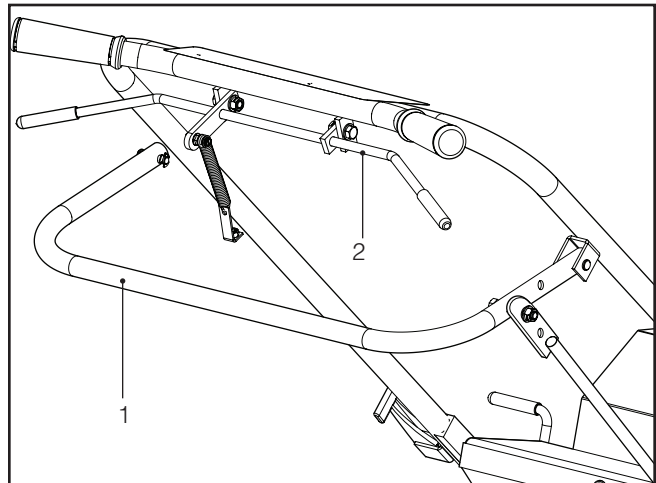

8060-003

1. Rear wheel control handle
2. Clutch control
Aerating controls

OPERATION

Transporting

Model 424

The BlueBird 424 Aerator has three convenient features to assist in transporting the unit in a pickup truck, van and even in some car trunks—removable weights, a folding handle and convenient lifting handles on the sides of the machine. The features are provided for optional use and can be of great benefit when required.



CAUTION!
DO NOT lift aerator with weights installed.

Removable Weights

- Unlatch weight locks.
- Grab weight handles and pull the weights from the machine.

Note: Weight 36 lb/16 kg each.

Folding Handle

- Release handle cam lock by lifting cam lever upwards. For handles with link lock—slide link up and hook links on upper handle pins.
- Fold handle forward over the engine until it is resting on the engine guard.

Lifting Handles

Lifting handles are located on both sides of the aerator, to allow two people to lift the unit.

Models 530 And 742

The removable weights are for side hill stability and tine penetration as applicable.

With the weights in place, these models are designed for easy loading and unloading on ramps and trailers. The treaded front wheel provides increased control during transport. Use engine power to load unit.

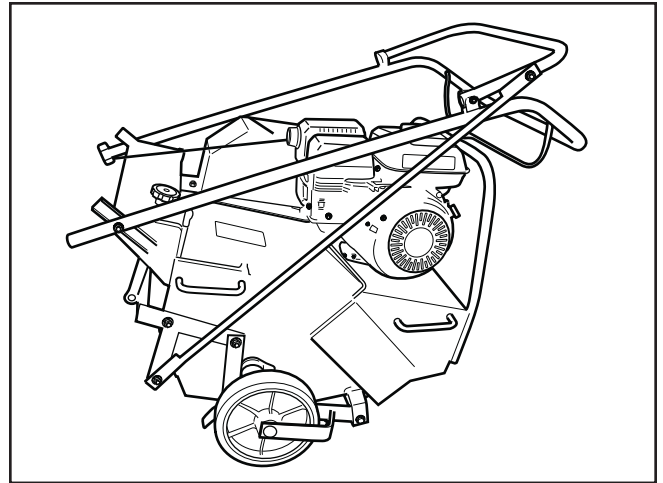

Remove weights and fold for transporting

8011-062-1



CAUTION!
Avoid back or muscle injury! Use safe lifting techniques, DO NOT exceed your physical limitations. DO NOT attempt to lift ALONE. Weight 193 lb/88 kg w/o weights.

MAINTENANCE AND SERVICE

Cleaning

Regular cleaning, washing and lubricating will prolong the service of the machine.

NOTE: Use care with power washers to avoid damage to warning decals, operator instruction labels, bearings, chains and engine. Limit direct spray on these items.

DO NOT EXCEED 1000 PSI WATER PRESSURE FOR CLEANING

Two Minute Rule

Aerators may be tipped on the engine guard for cleaning and access for no more than 2 minutes.

Engine damage may result from gasoline draining into the crankcase if prolonged. See engine manufacturer's operating and maintenance instructions.

INSPECTION SCHEDULE		Out of Box	First 5	Every 10	Each Use
Engine Oil		●			
Gear box oil		●			
Engine air cleaner		●			
Clutch and cable		●			●
Chain tension		●	●	●	
Belt wear and tension		●			●
Tine wear and condition		●			●
Fasteners		●		●	
Sprockets and set screws		●		●	
Frame condition		●		●	
Decals		●			●
LUBRICATION SCHEDULE	Lubricant	Every 20	Every 60	As Required	Storage
Engine	Oil ¹			●	
Gear Box	Oil ¹			●	
Rear Wheels	Lithium based grease		●	●	●
Chain	Graphite dry lubricant (aerosol)			●	●
Tires	Light machine oil				●
Linkage	30 W Oil	● ²			●

¹ - See Engine Owner's Manual

² - After each pressure wash or steam cleaning

MAINTENANCE AND SERVICE

Drive Train

Engine - removal and replacement

1. Remove weights for access.
2. Remove drive guard.
3. Remove V-Belt.
4. Remove engine bolts.
5. Lift engine from unit.

NOTE: Model 742 aerators equipped with optional Honda engines have two (2) pairs of shim plates under the engine.

6. Remove and retain V-pulley and key.
7. Replacement procedure opposite of removal.
8. Adjust drive belt and align V-pulley, see following section.

Drive Belt Replacement and Adjustment

1. Turn off engine and remove the drive guard cover.
2. Remove V-belt.
3. Inspect condition of V-pulleys and replace if necessary.
4. Check V-pulley alignment by looking down the belt with clutch engaged. Be sure both V-pulleys are directly in line with each other. Correct their alignment if not.
5. Install new belt over small V-pulley first, then over the large V-pulley.
6. Insure V-belt is inside both keeper arms.
7. Check that the V-belt clears the top belt keeper arm when idler is pulled tight. Check that the aerator rolls freely (with handle folded on Models 424 and 530), with the belt slack. Adjust the keeper, or clutch cable length if necessary.
8. For clutch adjustments refer to next section (Clutch Cable Removal and Replacement).
9. Replace drive guard.

Engine

Follow the engine manufacturers maintenance instructions. Should any malfunction occur with the engine during the warranty period, take it to an Authorized Service Dealer. DO NOT tear down the engine, as this may void the engine manufacturer's Warranty.

NOTE: Refer to engine manufacturer's Owners Manual for all engine service information.

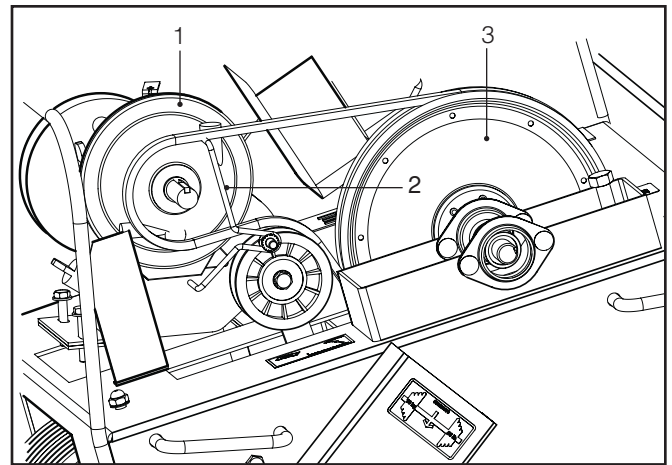

8060-010

1. Small pulley
2. Belt keeper
3. Large pulley

Replace belt on small pulley first

IMPORTANT INFORMATION

Many parts, including the drive belt on your aerator, are made specifically for BlueBird to give many hours of use. Replace all parts with genuine BlueBird parts to obtain maximum performance and unit life.

MAINTENANCE AND SERVICE

Clutch Cable

Removal and Replacement

1. Turn off engine and remove old clutch cable.
2. Route new cable through the hole at the rear of housing.
3. Attach clutch cable to the bracket on the spring on the idler assembly, then connect opposite end of cable to the S hook.
4. Adjust cable to obtain $\frac{3}{4}$ " to $1\frac{1}{4}$ " extension of the clutch spring when clutch is engaged.

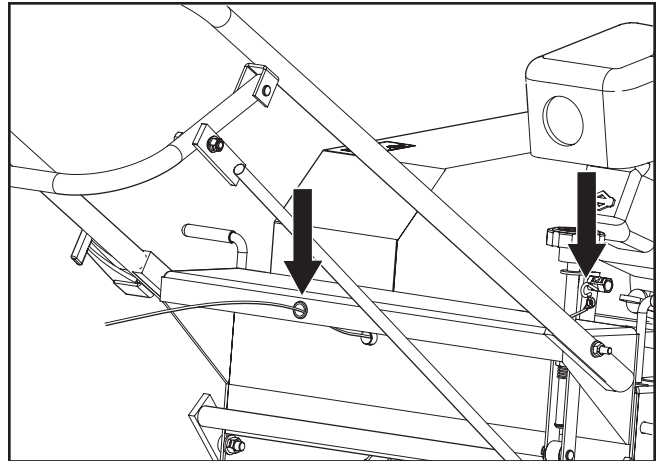

8060-002

Route clutch cable through guides

Throttle Cable

Removal and Replacement

1. Before removing your old cable measure the amount of cable extending past the cable screw.
2. Remove the old throttle cable and route the new cable through the guide hole at the rear of the housing.
3. Insert the new cable through the cable screw to the measurement obtained in step 1 and tighten.
4. Attach the new adjuster bracket to the spring on the throttle/clutch lever.

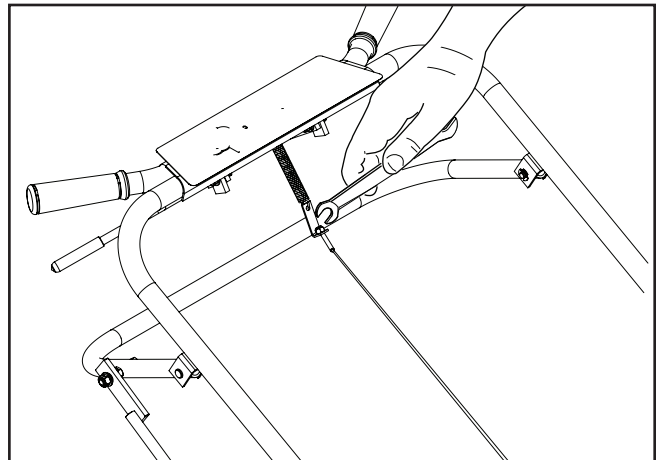

8060-013

Adjust cable

MAINTENANCE AND SERVICE

Throttle Cable

Model 742 (Honda Engine Only)

Adjustment

1. Start engine and allow it to reach operating temperature.
2. Adjust the throttle cable at the adjuster bracket by turning the adjuster nut. Tightening will increase engine speed, loosening will reduce engine speed.

NOTE: A properly adjusted throttle will slightly increase engine speed as the clutch engages.

- If the clutch engages too soon, the engine will stall.
- If the engine speed is too high, the gradual controlled start is lost.

As the cable length increases between the cable screw and adjuster nut the engine speed decreases. If engine speeds too low, the engine will stall as the clutch engages. As the cable length decreases between the cable screw and adjuster nut, the engine speed will increase. If engine speed is too high, the controlled start will be lost.

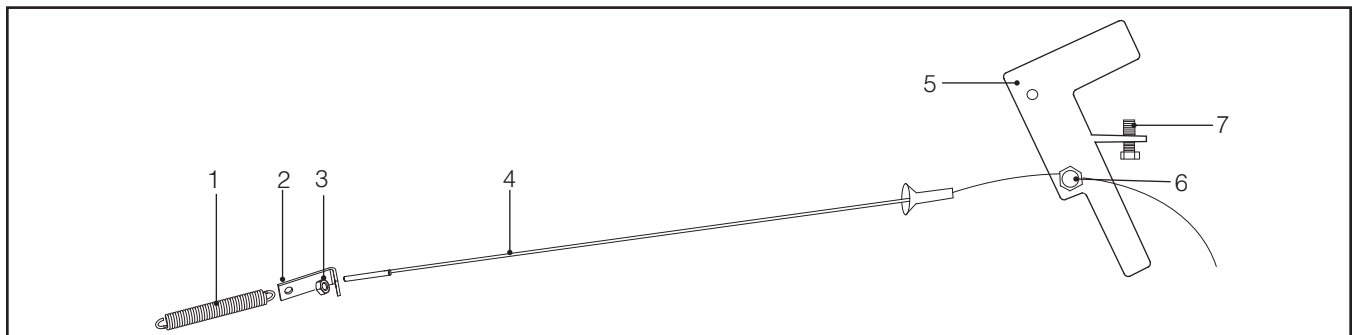

1. Throttle spring
2. Adjuster bracket
3. Adjuster nut

4. Throttle cable
5. Throttle lever

6. Cable screw
7. Stop screw

MAINTENANCE AND SERVICE

Chain

Removal and Replacement

1. Turn off engine.
2. Remove the drive guard.
3. Loosen chain idler adjustment bolt and lock nut.
4. Remove master link and remove chain.
5. Inspect and align sprockets. Check set screws. (Double set screws for wheel and rotor sprocket.)
6. Install new chain from top (drive sprocket side) as illustrated.

NOTE: Chain is most easily connected just behind the front drive wheel sprocket.

7. Install master link with pin plate on engine side of chain with keeper plate installed on outboard side. Install clip with split to front of machine.

Adjusting Tension

1. Turn engine off.
2. Remove drive guard, loosen lock nut on idler adjustment bolt.
3. Turn idler adjustment bolt to adjust tension to allow $\frac{1}{8}$ " to $\frac{1}{4}$ " movement at the center point between the wheel sprocket and the rotor sprocket
4. Tighten lock nut.

NOTE: BlueBird recommends the replacement of sprockets when replacing drive chain.

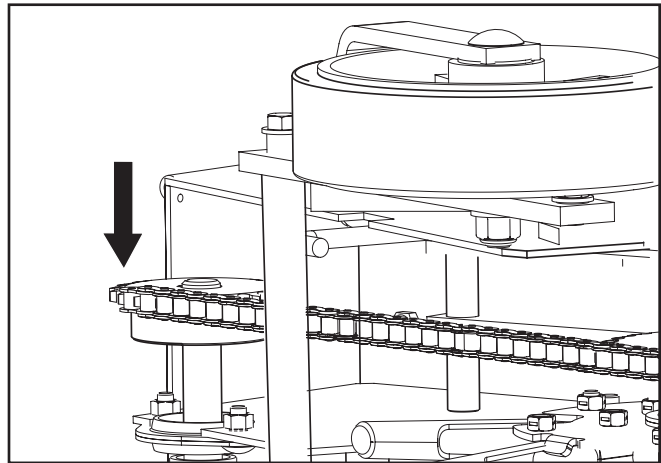

Inspect and align sprockets

8060-014

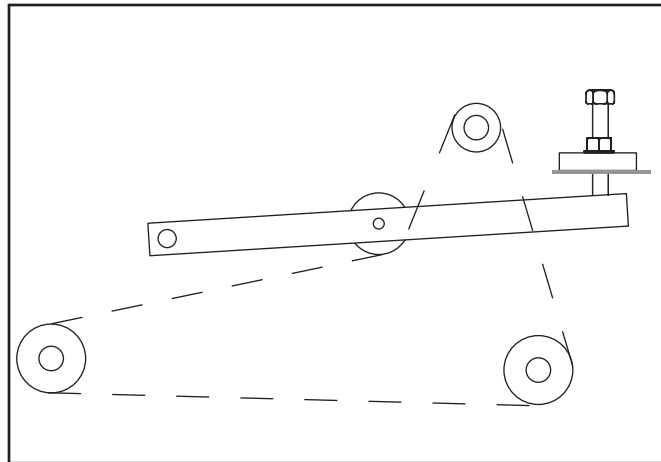

Chain routing

8060-009

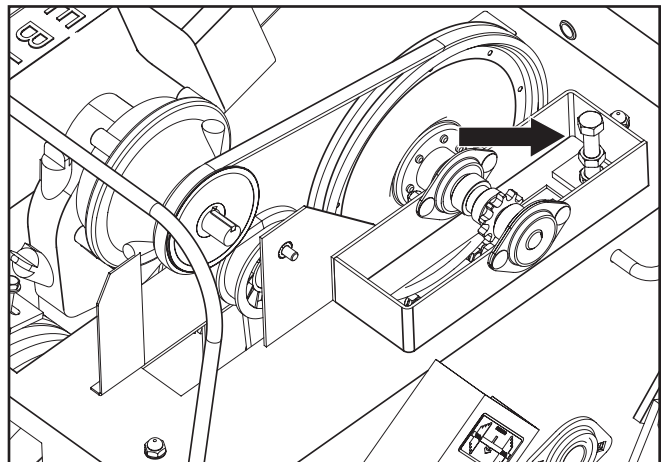

Idler adjustment bolt

8060-015

MAINTENANCE AND SERVICE

Tines

Tine Wear

After the BlueBird Aerator has been used for sometime, the tines will wear. When this happens aerating performance diminishes. Inspect tines using the drawing, replace when at minimum length or before. (Tines are 5" when new.)

Tine Replacement

1. Turn off engine and remove weights.
2. Fold handle on the 424 and 530 Models.
3. Place on workbench (Model 424 only) and chock wheels. Note direction of tine bolt. **Reinstall the bolt facing in the same direction on the Model 424 to avoid contact with weights.**
4. Remove and replace tines by loosening stop bolt. Remove retaining bolt and old tine, insert new tine and fasten with retaining bolt in the same direction as it was removed. When all tines are replaced, tighten stop bolts.

NOTE: Replace worn lock nuts to insure that bolts will hold tines in place.

Tine Shaft Bearing Removal and Replacement

1. Turn off engine and remove weights.
2. Remove drive guard cover.
3. Fold handle.
4. Elevate approximately 4", block and chock rear wheels.
5. Manually cycle the drive chain for access to master link.
6. Turn chain idler adjustment screw counter clockwise to loosen the chain.
7. Remove the master link and free rotor sprocket.
8. Remove the tine rotor shaft bearing bolts (4).
9. Remove chain scraper bolts (2) and chain scraper (on Model 424 only).
10. Remove the rotor shaft assembly.
11. Remove outer rotor bearing by loosening the set screw in the collar.
12. Reverse steps to reinstall.
13. Refer to sections "Chain Removal and Replacement" and "Adjusting Chain Tension" for chain replacement and adjustment of chain tension.

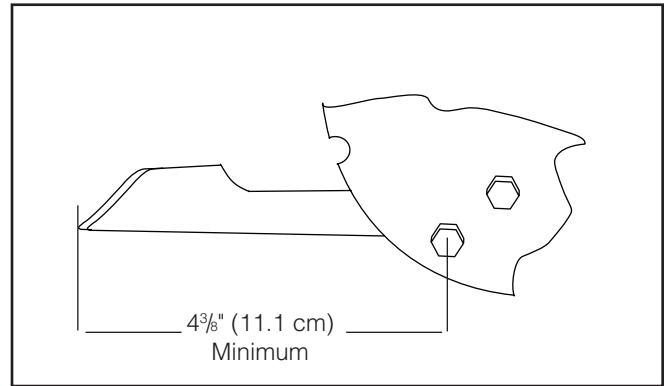

8060-011

Check tines for wear

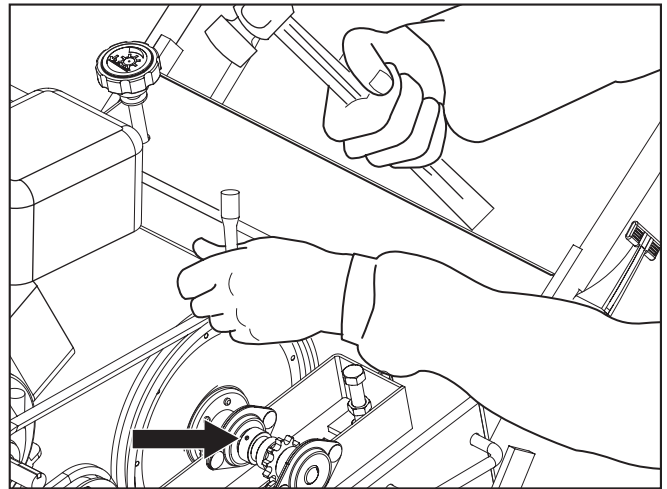

8060-012

Unlock inner bearing

14. Unlock collar (best accomplished by using a hammer and pin punch). Insert pin punch into the hole next to the set screw and, using the hammer and with moderate striking, hit collar so that it rotates in the opposite direction the rotor would normally turn.
15. Reverse steps to reinstall.
16. Refer to sections "Chain Removal and Replacement" and "Adjusting Chain Tension" for chain replacement and adjustment of chain tension.

MAINTENANCE AND SERVICE

Free-Wheeling Tine Assembly Removal and Replacement

Complete steps 1 through 12 in previous section, then proceed with the following:

1. After the bearing is off the rotor, unlock the inner bearing that secures the tine assembly.
2. Remove outer free-wheeling tine assembly.
3. Place the new rotor assembly beside the old assembly to have a pattern to follow indicating the correct direction for the new tine installation. The fixed tine assembly is also an example of proper installation.
4. Once the tines are installed on the free-wheeling assembly, reinstall the inner and outer bearing assemblies on the free-wheeling assembly. Face the bearing hubs toward the fixed tines. Make sure that the inner bearing has a locking collar. Hand tighten the nuts only.
5. Slide the new free-wheeling tine assembly onto the shaft, making sure that the tine direction matches the direction of the fixed tine assembly. The bearing with the locking collar faces the fixed tines and butts up against the shoulder of the shaft.
6. Tighten the four nuts on the bearing assemblies.
7. Lock the bearing collar in place with the hammer and punch making sure the collar locks in the same direction as the rotation of the rotor.
8. Replace outer shaft bearing and reinstall the entire rotor assembly by reversing steps 1 through 12 in previous action. Instructions are for one side. Both side are done with the same procedure.

Handle

Models 424 and 530, Cam Lock

Inspection

1. The handle cam lock must lock shut under moderately heavy hand pressure. The handle frame should be tightly secured to the aerator body.
2. Check the cam rod lock nut. If the lock turns freely by hand when cam is released, the nut must be replaced to maintain the security of the lock.

Adjustment

With the handle in the operating position, tighten the cam rod lock nut ($\frac{1}{4}$ turn at a time) until cam handle locks with moderately heavy hand pressure.

IMPORTANT: excessive adjustment of the lock nut will damage the cam rod. ALWAYS replace a free spinning nut to avoid unwanted loosening of the handle. For smooth operation of the cam, apply a small amount of grease on the cam edge.

Models 424 and 530, Link Lock

Inspection

The link lock needs only to have inspection for secure hardware and snug fit.

MAINTENANCE AND SERVICE

Wheels

Turn off engine and empty all fuel from the fuel tank
Remove weights and drive guard.

Loosen the lock nut on adjustment screw to loosen the chain. Remove master link and chain.

Tip the front end up to let the aerator rest on its handle. The front wheel will be approximately one foot off the ground.

1. Remove the four wheel shaft bearing bolts (4 on the 424 and 530 and 6 on the 742).



CAUTION!

Secure handle to prevent aerator from tipping.

2. Remove the wheel axle assembly.

Drive Wheel Shaft

Removal and Replacement

3. Pull sprocket and bearing from shaft.
NOTE: Sprocket is double set screwed. To remove the bearings, you must first remove the collar by loosening the set screw, then insert pin punch into the hole next to the set screw and, using a hammer, with moderate striking, hit collar so that it rotates in the opposite direction the wheel would normally turn. If bearings are rusted in place they will have to be replaced along with the wheel and shaft.
4. Install bearings and sprocket loosely onto the shaft. Models 424 and 530: hub side away from wheels. Model 742 has 3 bearings. Wheel bearings should have hubs facing away from wheel. Wheel shaft bearing should have hub facing away from sprocket.
5. Bolt bearings into place.
6. Center the wheels between the wheel opening and the housing. Lock the collars in place and tighten set screws.
7. Align and tighten the sprocket (there are double set screws stacked two in each hole) use blue loctite with the key in place.
8. Replace the chain following procedures in section "Chain Removal and Replacement".
9. Adjust chain per section "Adjusting Chain Tension" and replace drive guard.

IMPORTANT INFORMATION

Excessive adjustment of the lock nut will damage the cam rod. ALWAYS replace a free spinning nut to avoid unwanted loosening of the handle. For smooth operation of the cam, apply a small amount of grease on the cam edge.

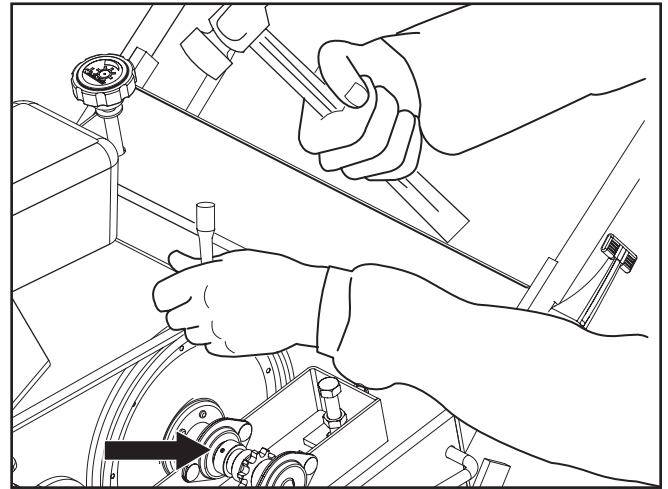

Collar punch pin hole

8060-012

MAINTENANCE AND SERVICE

Rear Wheels

Removal and Replacement Models 424 and 530

1. Make sure unit is on level ground and engine is turned off.
2. Lower the rear wheel control handle to let the aerator rest on the tines.
3. Turn the rear wheel depth/stability control knob to adjust the rear wheels for minimum depth clockwise (more stability).
4. Remove the axle nut. Pull the axle bolt, then the wheel from the wheel carriage.
5. Install a new wheel with grease fitting facing out, with seals carefully in place on the wheel bushing. Insert axle bolt through wheel and wheel lift frame. Use washer and lock nut, tighten firmly.
6. Grease wheel bearings.

Rear Wheel Removal and Replacement Model 742

1. Make sure unit is on level ground and engine is turned off.
2. Lower the rear wheel control handle to let the aerator rest on the tines.
3. Turn the rear wheel depth/stability control knob to adjust the rear wheels for minimum depth clockwise (more stability).
4. Remove the hairpin cotter pin.
5. Slide the wheel assembly off the machine.
6. Install hairpin cotter pin into the axle when removed to prevent loss.

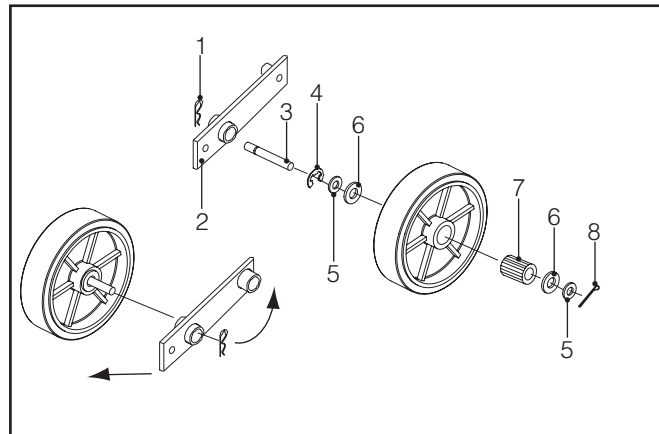

- | | |
|---------------|------------------|
| 1. Hair pin | 5. Washer |
| 2. Wheel arm | 6. Seal |
| 3. Wheel axle | 7. Wheel bushing |
| 4. E-clip | 8. Cotter pin |

Wheel removal, Model 742 only

TECHNICAL DATA

Power Unit	H424
Engine	
Manufacturer	Honda
Type	GX120K1HX2
Power	4 hp* / 2.98kW
Clutch	Belt Tensioner
Primary Drive	V-Belt
Secondary Drive	Permalube Chain
Gear Reduction	6:1
Wheels	
Bearings	Front - 3/4" (1.9 cm) sealed ball bearings with stamping kit Rear - 3/4" (1.9 cm) roller bearing
Rear Tires	8" x 2" (20 cm x 5 cm) solid rubber
Front Tire	10" x 6" (25 cm x 15 cm) semi-pneumatic
Aeration	
Tines	3/4" (1.9 cm) open spoon tine, 24 per unit
Aeration Width	17 1/2" (44.5 cm)
Hole Pattern	4 1/2" x 6 1/2" (11.2 cm x 16.5 cm)
Core Depth	Up to 3" (7.6 cm)
Holes per sq ft	6.7
Working Speed	250 ft/min (4.57 km/h)
Productivity	Up to 23,000 sq ft/hr (2137 m2/h)
Weights and Dimensions	
Net weight	265 lbs (120 kg)
Shipping weight	209 lbs (132 kg)
Removable weights	2 x 36 lbs (16.3 kg)
Height with handle folded	28" (71.1 cm)
Height overall	49 1/2" (126 cm)
Length with handle folded	40" (101.6 cm)
Length Overall	48" (122 cm)
Width	26 1/2" (67.3 cm)

*The power rating of the engines indicated is the average net power output (at specified rpm) of a typical production engine for the engine model measured to SAE standard J1349/ISO1585. Mass production engines may differ from this value. Actual power output for the engine installed in the final machine will depend on the operating speed, environmental conditions and other variables.

TECHNICAL DATA

Power Unit	H530A
Engine	
Manufacturer	Honda
Type	GX120K1HX2
Power	4 hp* / 2.98kW
Clutch	Belt Tensioner
Primary Drive	V-Belt
Secondary Drive	Permalube Chain
Gear Reduction	6:1
Wheels	
Bearings	Front - 3/4" (1.9 cm) sealed ball bearings with stamping kit Rear - 3/4" (1.9 cm) roller bearing
Rear Tires	8" x 2" (20 cm x 5 cm) solid rubber
Front Tire	10" x 6" (25 cm x 15 cm) semi-pneumatic
Aeration	
Tines	3/4" (1.9 cm) open spoon tine, 30 per unit
Aeration Width	19" (48.3 cm)
Hole Pattern	3 ⁴ / ₅ " x 6 ¹ / ₂ " (9.7 cm x 16.5 cm)
Core Depth	Up to 3" (7.6 cm)
Holes per sq ft	7.7
Working Speed	250 ft/min (4.57 km/h)
Productivity	Up to 25,000 sq ft/hr (2323 m ² /h)
Weights and Dimensions	
Net weight	288 lbs (131 kg)
Shipping weight	355 lbs (161 kg)
Removable weights	2 x 36 lbs (16.3 kg)
Height with handle folded	37" (94 cm)
Height overall	51 ¹ / ₂ " (130.8 cm)
Length with handle folded	39 ¹ / ₂ " (100.3 cm)
Length Overall	57 ¹ / ₂ " (146 cm)
Width	29 ³ / ₄ " (75.6 cm)

*The power rating of the engines indicated is the average net power output (at specified rpm) of a typical production engine for the engine model measured to SAE standard J1349/ISO1585. Mass production engines may differ from this value. Actual power output for the engine installed in the final machine will depend on the operating speed, environmental conditions and other variables.

TECHNICAL DATA

Power Unit	S530B
Engine	
Manufacturer	Subaru
Type	EH12-2
Power	4 hp* / 2.98kW
Clutch	Belt Tensioner
Primary Drive	V-Belt
Secondary Drive	Permalube Chain
Gear Reduction	6:1
Wheels	
Bearings	Front - 3/4" (1.9 cm) sealed ball bearings with stamping kit Rear - 3/4" (1.9 cm) roller bearing
Rear Tires	8" x 2" (20 cm x 5 cm) solid rubber
Front Tire	10" x 6" (25 cm x 15 cm) semi-pneumatic
Aeration	
Tines	3/4" (1.9 cm) open spoon tine, 30 per unit
Aeration Width	19" (48.3 cm)
Hole Pattern	3 ⁴ / ₅ " x 6 ¹ / ₂ " (9.7 cm x 16.5 cm)
Core Depth	Up to 3" (7.6 cm)
Holes per sq ft	7.7
Working Speed	250 ft/min (4.57 km/h)
Productivity	Up to 25,000 sq ft/hr (2323 m ² /h)
Weights and Dimensions	
Net weight	288 lbs (131 kg)
Shipping weight	355 lbs (161 kg)
Removable weights	2 x 36 lbs (16.3 kg)
Height with handle folded	37" (94 cm)
Height overall	51 ¹ / ₂ " (130.8 cm)
Length with handle folded	39 ¹ / ₂ " (100.3 cm)
Length Overall	57 ¹ / ₂ " (146 cm)
Width	29 ³ / ₄ " (75.6 cm)

*The power rating of the engines indicated is the average net power output (at specified rpm) of a typical production engine for the engine model measured to SAE standard J1349/ISO1585. Mass production engines may differ from this value. Actual power output for the engine installed in the final machine will depend on the operating speed, environmental conditions and other variables.

TECHNICAL DATA

Power Unit	H742
Engine	
Manufacturer	Honda
Type	GX120K1HX2
Power	4 hp* / 2.98kW
Clutch	Belt Tensioner
Primary Drive	V-Belt
Secondary Drive	Permalube Chain
Gear Reduction	6:1
Wheels	
Bearings	Front - 3/4" (1.9 cm) sealed ball bearings with stamping kit Rear - 3/4" (1.9 cm) roller bearing
Rear Tires	8" x 2" (20 cm x 5 cm) solid rubber
Front Tire	10" x 6" (25 cm x 15 cm) semi-pneumatic
Aeration	
Tines	3/4" (1.9 cm) open spoon tine, 42 per unit
Aeration Width	25.5" (64.8 cm)
Hole Pattern	3 3/5" x 6 1/2" (9 cm x 16.5 cm)
Core Depth	Up to 3" (7.6 cm)
Holes per sq ft	8.1
Working Speed	290 ft/min (5.3 km/h)
Productivity	Up to 40,000 sq ft/hr (3716 m2/h)
Weights and Dimensions	
Net weight	420 lbs (191 kg)
Shipping weight	487 lbs (221 kg)
Removable weights	2 x 36 lbs (16.3 kg)
Height with handle folded	28" (71.1 cm)
Height overall	52" (132 cm)
Length with handle folded	33" (83.3 cm)
Length Overall	54" (137 cm)
Width	38" (96.5 cm)

*The power rating of the engines indicated is the average net power output (at specified rpm) of a typical production engine for the engine model measured to SAE standard J1349/ISO1585. Mass production engines may differ from this value. Actual power output for the engine installed in the final machine will depend on the operating speed, environmental conditions and other variables.

TECHNICAL DATA

Torque Specifications Hex Head Cap Screws

The torque values shown should be used as a general guideline when specific torque values are not given.

U.S. Standard Hardware

	Grade	SAE Grade 5		SAE Grade 8		Flangelock Screw w/Flangelock Nut	
	ft./lbs	ft./lbs	Nm	ft./lbs	Nm	ft./lbs	Nm
Shank Size (Diameter in inches, fine or coarse thread)	1/4	9	12	13	18		
	5/16	18	24	28	38	24	33
	3/8	31	42	46	62	40	54
	7/16	50	68	75	108		
	1/2	75	102	115	156		
	9/16	110	150	165	224		
	5/8	150	203	225	305		
	3/4	250	339	370	502		
	7/8	378	513	591	801		
	1 1/8	782	1060	1410	1912		

** Grade 5 - Minimum commercial quality (lower quality not recommended)

Metric Standard Hardware

	Grade	Grade 8.8		Grade 10.9		Grade 12.9	
	ft./lbs	ft./lbs	Nm	ft./lbs	Nm	ft./lbs	Nm
Shank Size (Diameter in millimeters, fine or coarse thread)	M4	1.5	2	2.2	3	2.7	3.6
	M5	3	4	4.5	6	5.2	7
	M6	5.2	7	7.5	10	8.2	11
	M7	8.2	11	12	16	15	20
	M8	13.5	18	18.8	25	21.8	29
	M10	24	32	35.2	47	43.5	58
	M12	43.5	58	62.2	83	75	100
	M14	70.5	94	100	133	119	159
	M16	108	144	147	196	176	235
	M18	142	190	202	269	242	323
	M20	195	260	275	366	330	440
	M22	276	368	390	520	471	628
	M24	353	470	498	664	596	794
	M27	530	707	474	996	904	1205



68 S Squirrel Rd
Auburn Hills MI 48326